



Usage of SV 102 and SV 102A Noise Dosimeters with SV 25S Microphone in Real Ear Technique (MIRE)



Short User Guide

Warsaw, March 2011

Please read the whole user guide before
assembling the SV 25S microphone kit
IT IS VERY IMPORTANT.

Table of Contents:

1. Introduction	3
2. Elements of the SV 25S set.....	4
3. Assembling of the SV 25S microphone.....	5
4. Calibration of SV 25S microphone.....	8
5. Using SV 25S microphone.....	9

1. Introduction.

Microphone In Real Ear (MIRE) is a technique for assessing the noise sources placed in a short distance to a human ear.

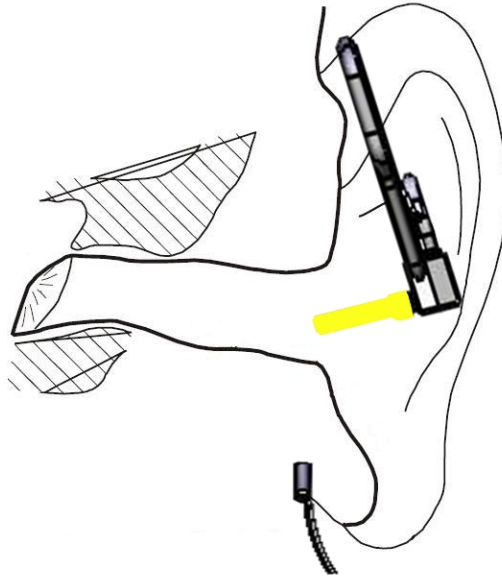

SV 25S microphone measures sound pressure level in the ear canal by means of the probe which is placed at the entry to the ear canal. The length of the probe is 16mm to ensure the maximum comfort and protect from contact with the eardrum.

To prevent any damage of the eardrum or skin and ensure the hygienic comfort, the probe tube is covered by disposable silica pipe.

SV 25S is dedicated to be used with SV 102 and SV 102A Noise Dosimeters.

For usage of SV 25S microphone the appropriate digital correction filter is required. For this reason, the SV 25S cannot be used with any other SLM than SV 102 or SV 102A.

Microphone must be connected to the SV 102 (or SV 102A) instrument in the first turn! After this step instrument can be switched on.

SV 102 instrument automatically detects type of microphones connected and activates the appropriate compensation filters.

Because historically SV 25S microphone was used with different length probes ensure that the appropriate probe length is selected in the instrument's menu.

Depending on this setting the adequate compensation filter is activated!

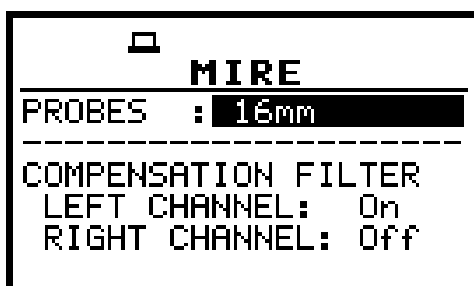

In order to choose the appropriate compensation filter, user has to select the **PROBES length** in the menu SETUP\MIRE and press the <ENTER>.

Instrument detects SV 25S automatically signaling it in menu SETUP\MIRE as ON/OFF

2. Elements of the complete set: SV 25S and SA131 calibration adapter.

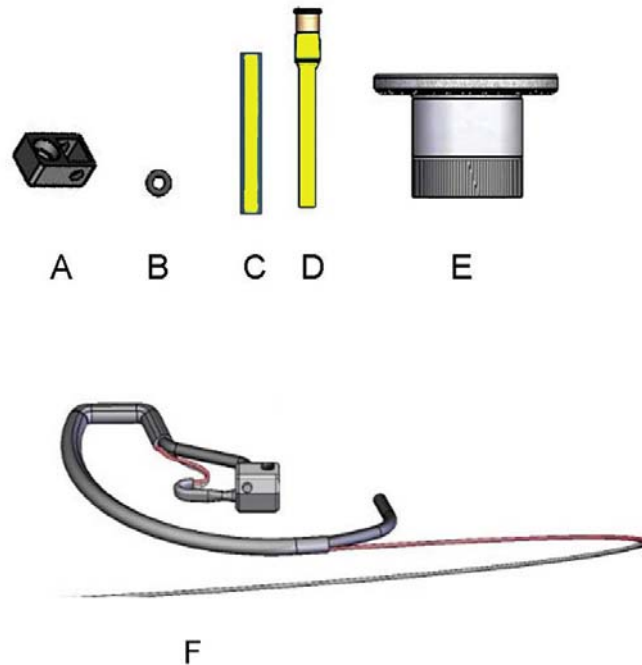

SV 25S complete set consists of following elements:

- A. Microphone housing (2 pieces – one spare part)
- B. O-ring (2 pieces- one spare part)
- C. Silica pipe for the yellow probe (SA125 16mm), in standard there is one pack containing 45 pieces
- D. Yellow probe (SA25S 16mm), in standard 2 pieces are delivered (one spare part)
- E. Calibration adapter SA131 (optional)
- F. Over-ear microphone

3. Assembling of the SV 25S microphone.

Microphone SV 25S is not a ready-to-use product. This fact is caused by necessity of adopting the microphone to the individual ear features of person who is going to wear the microphone.

To assemble the SV 25S microphone user must follow five steps:

Step one: dismount the ending of the over-ear microphone of the side hole of element A

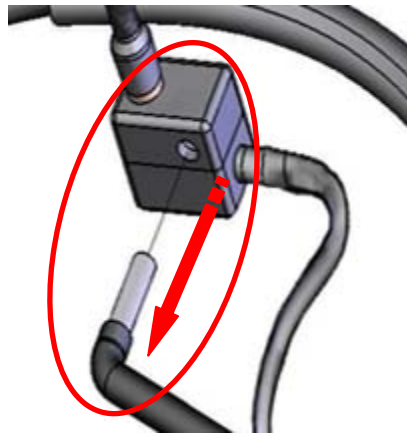

Step two: dismount the microphone housing (element A) from the over-ear microphone (K).

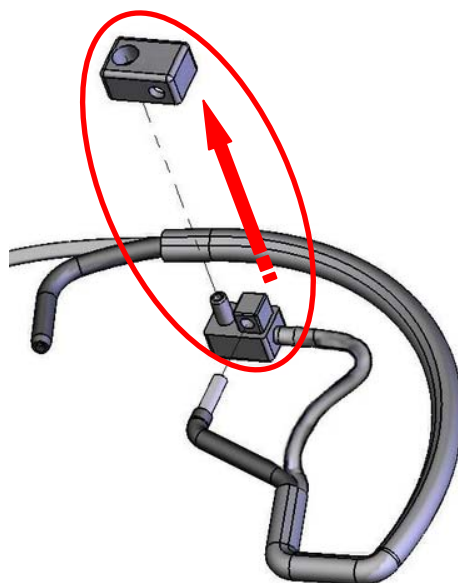

Step three: place the microphone probe (D/F) on the connector making sure that one o-ring (B) is placed between probe and connector. In a new set the o-ring is already mounted on the connector.

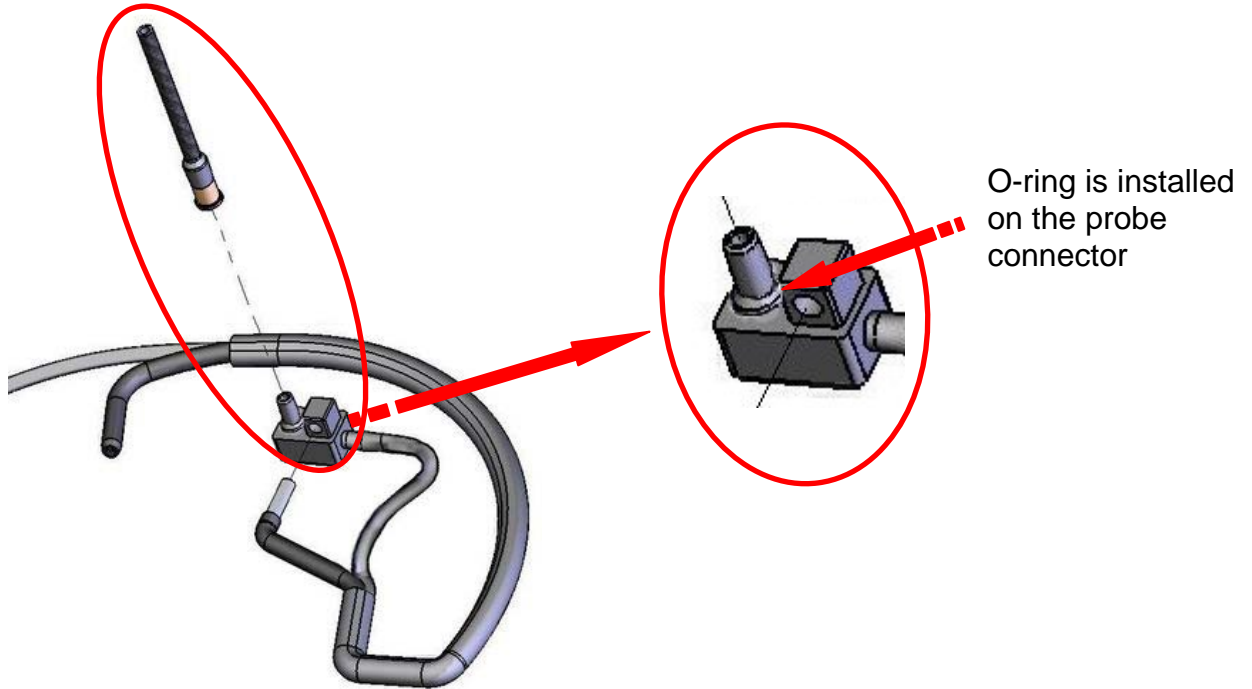

Use the spare o-ring only in case the original one is not placed on the connector:

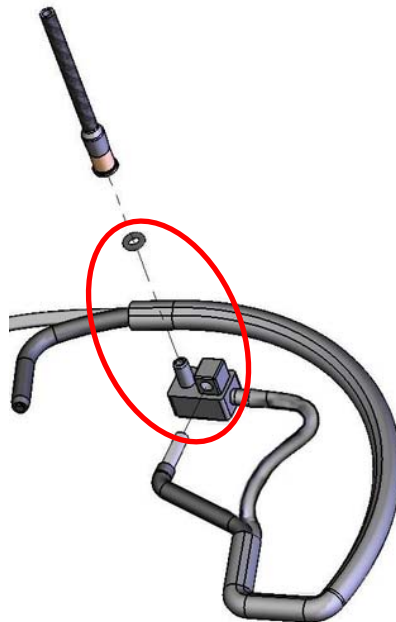

Step four: mount the microphone housing (A) on the probe putting the probe through the hole on the top of element A.

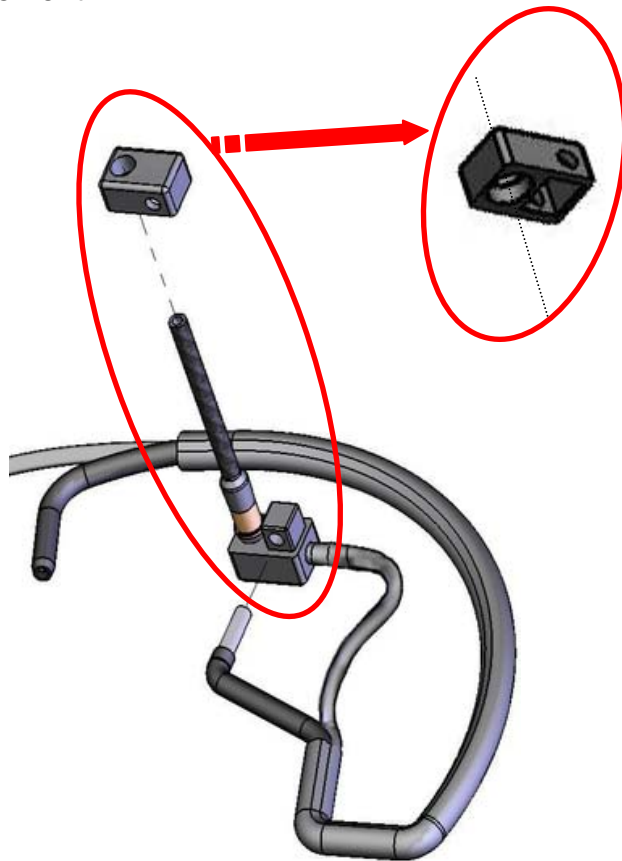

Step five: connect the ending of the over-ear microphone to the side hole of element A.

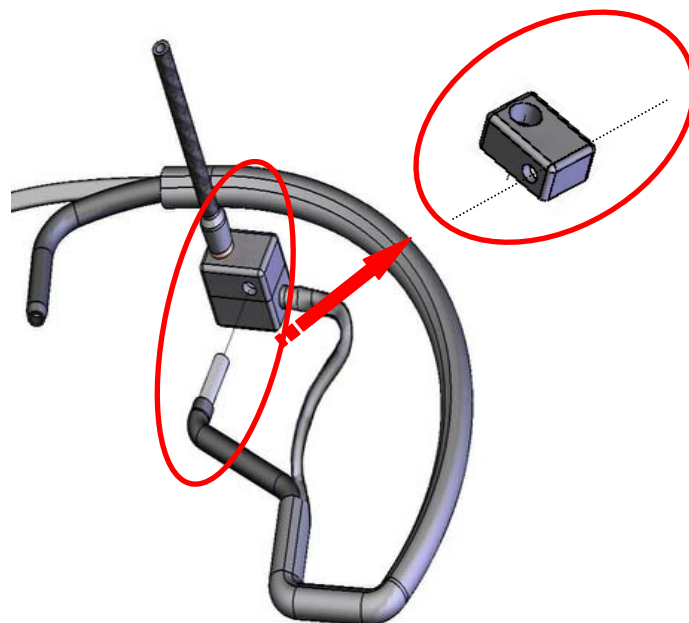

4. Calibration of the SV 25S microphone with SV30/SV31 acoustic calibrator.

SA 131 adapter is required to calibrate SV 25S with 1/2" acoustic calibrator. Place the SV 25S probe inside the calibration adapter and then put them inside the acoustic calibrator.

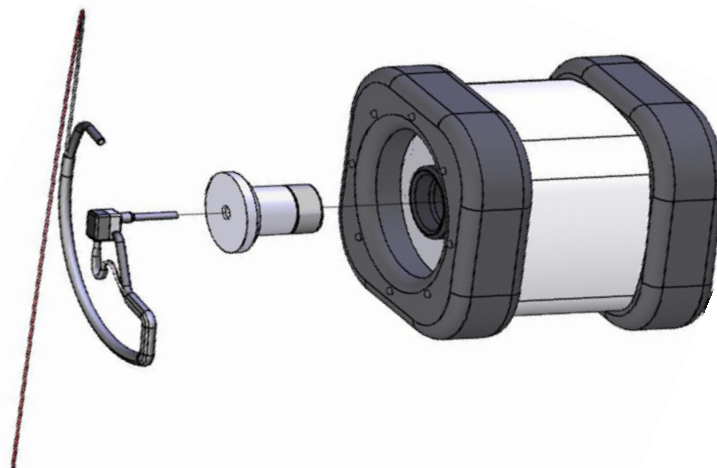

IMPORTANT NOTE!!

Sound pressure generated by calibrators **other than SV 30A & SV 31** at the SV 25S microphone may vary from the nominal level of the calibrator because of different air volume comparing to classic 1/2" microphones.

Therefore a correction is necessary for some calibrators:

SV 30A correction is not necessary (0.0dB)

SV 31 correction is not necessary (0.0dB)

SV 32 correction factor equals to (-0.15dB)

Correction factor must be added to the nominal level of the calibrator indicated in calibration certificate of the calibrator.

Example:

Suppose SV 32 calibration level is 94.1dB.

The calibration level that suppose to be typed in during calibration of SV102 is 93.95dB

Calibration procedure of the instrument is described in
Chapter 5 of SV 102 User Manual

5. Using the SV25S microphone.

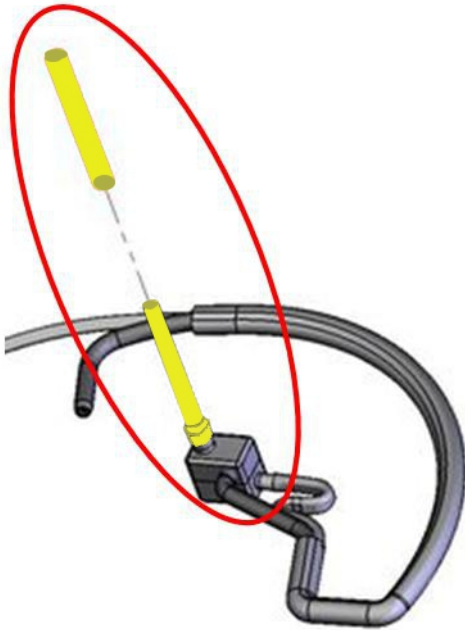

Before placing the SV 25S microphone in the ear remember to put the silica pipe on the probe.

Color and length of silica pipe should match the probe's.

When calibration process is finished SV 25S is ready to use. Pictures show the correct placing of the microphone on the human's ear:



Take caution whenever the microphone is placed inside the human ear. Correct position for probe placement is the entry of the ear channel **not inside of it!** Otherwise sudden movements of the user or unexpected blows around ear area may cause serious injuries if enough carefulness is not kept.